

The Stream Engine

Personal Hydropower

Owner's Manual

PLEASE READ CAREFULLY

Made in Canada

by

Energy Systems and Design Ltd.

PO Box 4557

Sussex NB

Canada E4E 5L7

Phone +1 (506) 433-3151

Fax +1 (506) 433-6151

Email: support@microhydropower.com

Website: www.microhydropower.com

The **Stream Engine** is a Trademark of Energy Systems & Design Ltd.

Congratulations on your purchase of a new *Stream Engine*! With a proper installation and a little routine maintenance, your Stream Engine will provide you with years of trouble-free operation. This manual will help you to install your Stream Engine as well as assist you in trouble-shooting and problem solving. Of course, you may contact Energy Systems & Design Ltd. if you run into trouble.

May your RE adventures prove successful!

PLEASE READ CAREFULLY

It is very important to keep the alternator rotor from contacting the stator (the stationary part under the rotor). If this occurs, serious damage may result.

Whenever you are operating the machine with a small air gap (distance between alternator rotor and stator) you should check the gap whenever an adjustment is made!

Do this by inserting a shim (0.015" or 0.25mm thick), or something thicker in the gap when the rotor is stationary (hint: most business cards are 0.010" thick, therefore, using two cards of this thickness could be used to check the air gap). Check all the way around the rotor. This is also a way to check for bearing wear on a monthly basis. If you **cannot** easily insert the shim into the gap, either all or in part, it is necessary to adjust the rotor upward (see *Output Adjustment* in this manual). **DO NOT USE** steel feeler gauges as they will be attracted to the magnets.

When making air gap adjustments, make sure the larger bolt is tightened (clockwise) against the shaft and the smaller bolt is also tightened (clockwise); so as to lock both parts in place.

Table of Contents

| | |
|--|-------|
| 1. Introduction..... | 3 |
| 2. Site Evaluation | 3 |
| 3. Head Measurement | 3 |
| 4. Flow Measurement..... | 4 |
| 5. Intake, Pipeline & Tailrace | 5-6 |
| 6. Batteries, Inverters & Controllers | 7 |
| 7. Wiring and Load Center..... | 8 |
| 8. Design Example | 8-9 |
| 9. Output Adjustment..... | 10 |
| 10. High Voltage Models | 11 |
| 11. The Universal Nozzle | 11 |
| 12. <i>Nozzle flow chart</i> | 11 |
| 13. Bearings, Service and Assembly | 12 |
| 14. <i>Copper Wire Resistance Chart</i> | 13 |
| 15. <i>Pipe Friction Head Loss Charts</i> | 14-15 |
| 16. <i>Stream Engine Output in Watts Table</i> | 16 |
| 17. Wiring Diagrams..... | 17 |
| 18. Wiring Schemes | 18 |
| 19. Current Measurement Technique..... | 18 |
| 20. Installation Examples..... | 19-20 |

INTRODUCTION

This manual describes **The Stream Engine**, which is manufactured by Energy Systems and Design Ltd. The installer must have some knowledge of plumbing and electrical systems, and the user of the system should also. These machines are small, but can generate some very high voltages. Even 12-volt machines can produce high voltages under certain conditions. Practice all due safety. Electricity cannot be seen and can be lethal.

It is important to consult with local officials before conducting any watercourse alteration. ES&D advises following all local laws and ordinances regarding watercourses.

Electricity is produced from the potential energy in water moving from a high point to a lower one. This distance is called "head" and is measured in units of distance (feet, meters) or in units of pressure (pounds per square inch, kilo-Pascals). "Flow" is measured in units of volume (gallons per minute - gpm, or liters per second - l/s), and is the second portion of the power equation. The power available is related to the head and the flow.

The Stream Engine is designed to operate over a wide range of heads and flows. This is achieved with the use of a Turgo runner, or wheel. Nozzle diameters of 1/8 to 1 inch are available, and up to four nozzles can be used on one machine, to utilize heads as low as four feet and as high as hundreds.

The Stream Engine uses a permanent magnet type alternator. This design eliminates the need for brushes and the maintenance that accompany them while increasing efficiency. The Stream Engine's output can be optimized by simply adjusting the rotor clearance.

SITE EVALUATION

Certain information must be determined concerning your site, in order to use its potential for maximum output. Head and flow must first be determined. Other factors are: pipeline length, transmission distance, and the system voltage. These factors determine how much power can be expected.

Power is generated at a constant rate by the Stream Engine and stored in batteries as direct current (DC). Power is supplied, as needed, by the batteries, which store energy during periods of low consumption for use in periods where consumption exceeds the generation rate. Appliances can be used that operate directly from batteries, or 120 volt alternating current (AC) power can be supplied through an inverter, converting DC to AC power.

Sites may vary, so carefully consider flow and head when choosing yours. Remember, maximum head can be achieved by placing the Stream Engine at as low an elevation as possible, but going too low may cause the machine to become submerged (or washed away!).

HEAD MEASUREMENT

Head may be measured using various techniques. A garden hose or length of pipe can be submerged with one end upstream and the other end downstream. Anchor the upstream end with rocks or have an assistant hold it; water should flow out the low end, especially if the pipeline is pre-filled. Once water is flowing, raise the downstream end until it stops. Do this slowly since the water tends to oscillate. When the flow has stabilized, measure the distance down to the level of water in the stream with a tape measure. This will give a very accurate measurement of that stream section. Mark the spot and then repeat the procedure until the entire distance is covered.

Another technique is to use a surveyor's transit. This method can also be approximated using a carpenter's level using a measuring stick or a "story pole." This technique is also done in a series of steps to arrive at the overall head. A variation on this method is the use of altimeters. GPS equipment could also be used to measure elevation.

FLOW MEASUREMENT

The easiest method to measure small flows is to channel the water into a pipe using a temporary dam and to fill a container of known volume. Measuring the time to fill the container enables you to calculate the flow rate.

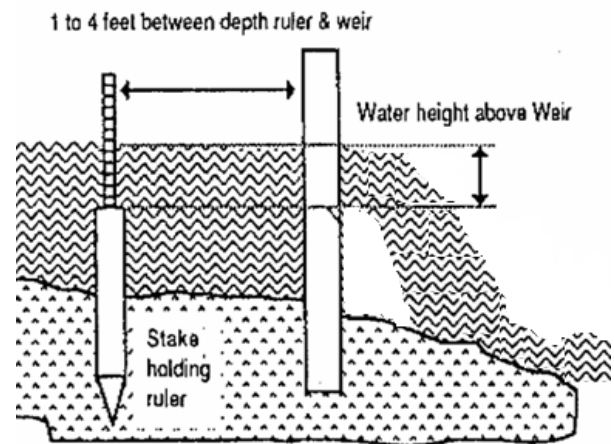
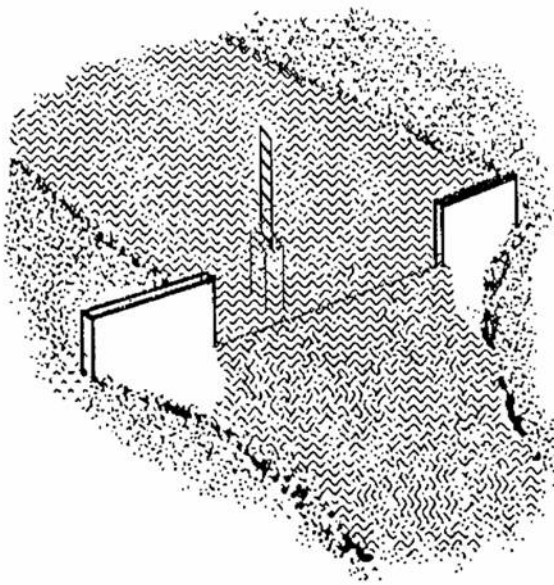

WEIR MEASUREMENT TABLE

Table shows water flow in gallons/minute (gpm) that will flow over a weir one inch wide and from 1/8 to 10-7/8 inches deep.

| Inches | | 1/8 | 1/4 | 3/8 | 1/2 | 5/8 | 3/4 | 7/8 |
|--------|------|------|------|------|-------|-------|-------|-------|
| 0 | 0.0 | 0.1 | 0.4 | 0.7 | 1.0 | 1.4 | 1.9 | 2.4 |
| 1 | 3.0 | 3.5 | 4.1 | 4.8 | 5.5 | 6.1 | 6.9 | 7.6 |
| 2 | 8.5 | 9.2 | 10.1 | 10.9 | 11.8 | 12.7 | 13.6 | 14.6 |
| 3 | 15.5 | 16.5 | 17.5 | 18.6 | 19.5 | 20.6 | 21.7 | 22.8 |
| 4 | 23.9 | 25.1 | 26.2 | 27.4 | 28.5 | 29.7 | 31.0 | 32.2 |
| 5 | 33.4 | 34.7 | 36.0 | 37.3 | 38.5 | 39.9 | 41.2 | 42.6 |
| 6 | 43.9 | 45.3 | 46.8 | 48.2 | 49.5 | 51.0 | 52.4 | 53.9 |
| 7 | 55.4 | 56.8 | 58.3 | 59.9 | 61.4 | 63.0 | 64.6 | 66.0 |
| 8 | 67.7 | 69.3 | 70.8 | 72.5 | 74.1 | 75.8 | 77.4 | 79.1 |
| 9 | 80.8 | 82.4 | 84.2 | 85.9 | 87.6 | 89.3 | 91.0 | 92.8 |
| 10 | 94.5 | 96.3 | 98.1 | 99.9 | 101.7 | 103.6 | 105.4 | 107.3 |

Example of how to use weir table:

Suppose depth of water above stake is 9 3/8 inches. Find 9 in the left-hand column and 3/8 in the top column. The value where they intersect is 85.9 gpm. That's only for a 1-inch weir, however. You multiply this value by the width of your weir in inches to obtain water flow.

The weir method is more versatile and may prove useful for higher flows. This technique uses a rectangular opening cut in a board or piece of sheet metal set into the brook like a dam. The water is channeled into the weir and the depth is measured from the top of a stake that is level with the edge of the weir and several feet upstream. Looking at the chart that follows will enable you to convert the width and depth of flowing water into gallons per minute.

Measuring the flow at different times of the year helps you estimate maximum and minimum usable flows. If the water source is seasonally limited, you may have to depend on some other source of power during dry times (solar, wind). Keep in mind that a reasonable amount of water must be left in the stream (Don't take it all, that water supports life forms).

When head and flow are determined, the expected power output can be determined from the following chart. Keep in mind that chart values represent *generated* output and that actual power delivered to the batteries will be reduced by transmission lines, power converters, and other equipment required by the system. All systems should be carefully planned to maximize power output.

Stream Engine Output in Watts (Continuous)

| Net Head | | Flow Rate | | | | | | |
|----------|------|--------------------------|--------------|--------------|--------------|---------------|---------------|---------------|
| | | Liters/sec (Gallons/min) | | | | | | |
| Meters | Feet | 0.67 (10) | 1.33 (20) | 2.50 (40) | 5.00 (75) | 6.67 (100) | 7.50 (112) | 9.50 (150) |
| 3 | 10 | - | 20 | 40 | 75 | 100 | 130 | 150 |
| 6 | 20 | 15 | 40 | 80 | 150 | 200 | 250 | 350 |
| 15 | 49 | 45 | 100 | 200 | 375 | 500 | 650 | 800 |
| 30 | 98 | 80 | 200 | 400 | 750 | 1000 | * | * |
| 60 | 197 | 150 | 400 | 800 | 1500 | * | * | * |
| 90 | 295 | 200 | 550 | 1200 | * | * | * | * |
| 120 | 394 | 300 | 700 | 1500 | * | * | * | * |
| 150 | 492 | 400 | 850 | 1900 | * | * | * | * |

* In these higher output situations, it may be worthwhile to utilize more than one Stream Engine.

INTAKE, PIPELINE, AND TAILRACE

Most hydro systems require a pipeline. Even systems operating directly from a dam require at least a short plumbing run. It is important to use the correct type and size of pipe to minimize restrictions in the flow to the nozzle(s). When possible, pipelines should be buried; this stabilizes the line and prevents animals from chewing it.

At the inlet of the pipe, a filter should be installed. A screened box can be used with the pipe entering one side, or add a section of pipe drilled full of holes wrapped with screen or small holes and used without screen. Make sure that the filter openings are smaller than the smallest nozzle used. Note that particles over about ¼" or 6mm in size may lodge in the runner.

The intake must be above the streambed so as not to suck in silt and should be deep enough so as not to suck in air. The intake structure should be placed to one side of the main flow of the stream so that the force of the flowing water and its debris bypasses it. Routinely clean the intake of any leaves or other debris.

If the whole pipeline doesn't run continuously downhill, at least the first section should, so the water can begin flowing. A bypass valve may be necessary. This should be installed at a low point in the pipe.

For pipelines running over dams, or in conditions that create a siphon, the downstream side may be filled by hand. Once filled, the stop valve at the turbine can be opened to start the flow. If full pressure is not developed, or air builds up in the line, a hand-powered vacuum pump can be used to remove air trapped at the high point.

At the turbine end of the pipeline a bypass valve may be necessary to allow water to run through the pipe without affecting the turbine, purging the line of air or increasing flow to prevent freezing.

A stop valve should be installed upstream of the nozzle. A pressure gauge should be installed upstream of the stop valve so both the static head (no water flowing) and the dynamic head (water flowing) can be read.

The stop valve on a pipeline should always be closed slowly to prevent water hammer (the column of water in the pipe coming to an abrupt stop). This can easily destroy your pipeline and for this reason, you may wish to install a pressure relief valve just upstream of the stop valve. This can also occur if debris clogs the nozzle. In a single nozzle machine a nozzle that becomes clogged suddenly may create a water hammer.

Nozzles can be installed or changed by removing the nozzle. The nozzle is removed by unscrewing its four nuts using an 11mm (7/16") wrench. The use of flexible pipe makes it easier to remove the plumbing from the nozzles.

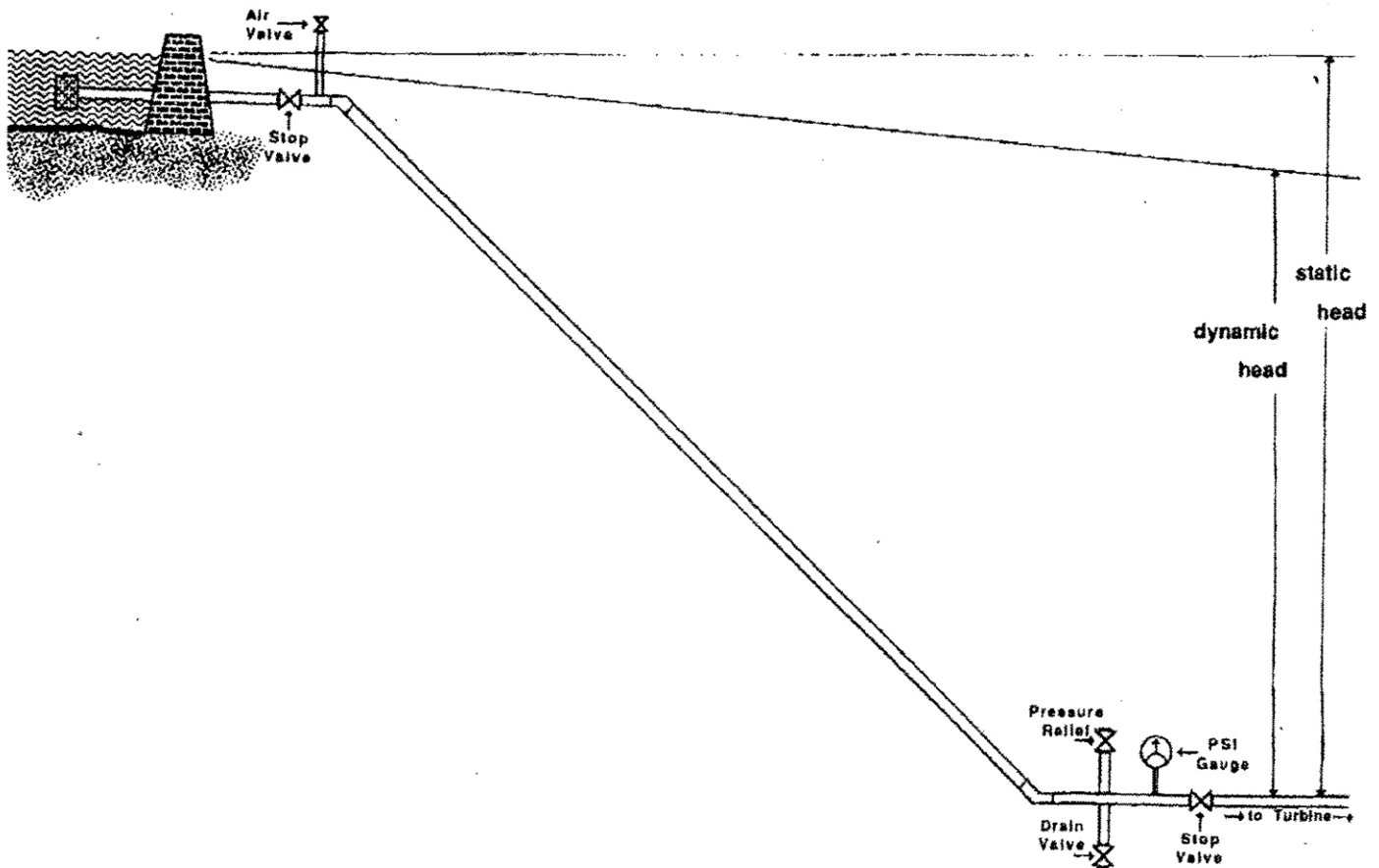

The turbine housing can be mounted on two boards to suspend it above the stream. It is recommended to have the Stream Engine in a small enclosure or under some cover to keep it dry and provide a place for auxiliary equipment.

Mounting the machine in concrete is also possible (you may wish to try a temporary wood mounting first). The opening under the housing to catch the water should be at least the size of the turbine housing opening, and preferably a little larger. Make certain the tailrace (exit channel) provides enough flow for the exiting water. The housing opening is 9-1/2 inches square, the bolt holes are on an 11-inch square, and the housing is 12 inches square. The diameter of the bolt holes is 1/4" (6mm).

In cold climates, it may be necessary to build a "trap" into the exit. This prevents outside air from entering the housing and causing freeze-ups.

BATTERIES, INVERTERS & CONTROLLERS

System Voltage

A small system with a short transmission distance can be designed to operate at 12 volts. Larger systems can also be 12 volts, but if higher power is desired or the transmission distance is long, then a system of 24 volts or higher may be preferable. This is especially true if all loads are inverter-powered. In a 12-volt system operating at a low power level, it may be advantageous to operate all loads directly from batteries. Many 12-volt appliances and small inverters are available. In 24-volt systems, it may also be preferable to operate the loads directly (although not as many appliances are available).

In higher power systems, it is usually better to use an inverter to convert battery voltage to regular 120 volt AC power at 60Hz (cycles per second), or 240 volt 50Hz in some countries. This has been made feasible with the advent of reliable high power inverters. Thousands of home power systems are in operation with only AC loads.

Sizing Battery Bank

A typical hydro system should have about one or two days of battery storage capacity. This will generally keep lead-acid cells operating in the middle of their charge range where they are the most efficient and long-lived.

Batteries should be located outside of any living space, or adequate ventilation should be provided, as a rising charge level tends to produce both hydrogen gas and corrosive fumes. Also, the water consumption increases; distilled water should be used to maintain the water level.

Charge Control

Unlike solar systems, a hydro system must always be connected to a load even when the batteries are fully charged. If the output power does not have a load, system voltage can rise to very high levels. This situation provides an opportunity to do something with the excess power, for example, a dump load can be used for water or space heating.

As the batteries become fully charged, their voltage rises. At some point, the charging process should stop and the power be diverted to the dump load (there is a fair bit of guesswork involved here). The voltage set-point should be about 13.5 to 14.5 for a 12-volt system, or set points proportionately for other voltage systems, depending on the charge rate. The higher the charge rate, the higher the voltage can go. Most charge controllers permit different charge levels such as bulk, absorption, and float. Literature supplied with the controller should be consulted to determine the set points of the charge controller.

Watt-Hour meters are available that monitor the battery state of charge.

An ammeter that monitors turbine output should always be installed in a high traffic or living space so difficulties with the machine can be easily detected. If a drop in output is noticed, the machine should be inspected. This could be caused by air in the pipeline, or a blocked or partially blocked nozzle. More importantly, a drop in output could be the beginning of bearing failure. Bearing failure will cause serious damage to the machine. Early detection of problems with the bearings is vital.

WIRING AND LOAD CENTER

Every system requires some wiring to connect the various components. Load centers are available as a complete package that easily facilitates the connection of loads and power source(s). All circuits in the system should use wire of adequate size and have fuses or breakers of sufficient capacity to carry the expected load current. The Stream Engine must be fused since it can suffer from a short or similar fault just like anything else in the system.

Inside the junction box on the side of the machine are two terminal blocks for the battery wiring. The negative terminal is bolted to the box and the positive terminal is bolted to the plastic plate. Your transmission wire ends are inserted into these two connectors (after being stripped of insulation) and then tightened. Make sure that the battery wiring is correctly connected or the rectifier will be destroyed. Do not operate the machine without being connected to the batteries as very high voltages may be generated.

The multi-meter connected to the shunt terminals (see *new current measurement technique, pg. 19*) will measure current output and is used when adjusting the output. A voltmeter connected to the batteries will roughly indicate the charge level, as described in Charge Level above.

DESIGN EXAMPLE

This example shows how to proceed with a complete installation. The parameters of the example site are:

- 120 feet of head over a distance of 1000 feet
- a flow of 30 gpm (most of the time)
- 100 feet of distance from the house to the hydro machine
- 24 volt system

The first thing we do is determine the pipeline size. Although maximum power is produced from a given size pipe when the flow loss is 1/3 of the static head, more power can be obtained from the same flow with a larger pipe, which has lower losses. Therefore, pipe size must be optimized based on economics. As head decreases, efficiency of the system decreases, and it is important to keep the head losses low.

The pipe flow charts show us that two-inch diameter polyethylene pipe has a head loss of 1.77 feet of head per 100 feet of pipe at a flow rate of 30 gpm. This is 17.7 feet of loss for 1000 feet of pipe.

Using two-inch PVC gives us a loss of 1.17 feet of head per 100 feet of pipe or 11.7 feet for 1000 feet.

Polyethylene comes in continuous coils because it is flexible (and more freeze resistant). PVC comes in shorter lengths and has to be glued together or purchased with gaskets (for larger sizes). Let's say we select polyethylene.

The maximum output occurs with a flow of about 45 gpm since that gives us a head loss of 3.75 feet per 100 feet of pipe, or 37.5 feet of loss for our 1000 feet of pipe. This is 37.5' loss/120' head = 31% loss.

A flow of 30 gpm gives a net head of 102.3 feet (120' - 17.7'). The losses caused by the various pipe fittings and intake screen will further decrease the dynamic head, so 100 feet is a good working figure for the net head.

At this head and flow condition, the output of the machine is equal to about 300 watts.

Since we require 24 volts and the transmission distance is fairly short, we can generate and transmit 24 volts using the Stream Engine. This Stream Engine could also be used for higher voltages 48 and 120 or 240. With higher voltages, power could be transmitted longer distances.

Looking at the nozzle flow chart, we see that a 3/8" nozzle will produce a flow of 27.6 gpm at a 100' head. This is very close to the design point but will produce slightly less output than if we had exactly 30 gpm. A 7/16" nozzle would produce slightly greater flow and output, but with more head loss. We need to go 100' with 300 watts at our site. This will be about 10 amps at 30 volts at the generator. Note that there will be some voltage drop in the line and 24-volt batteries require somewhat higher voltages than nominal to become charged. So the 10 amps must pass through 200' of wire for the round trip. Resistance losses should be kept as low as economics permit, just like the pipeline losses.

Let's say we wish to have around a 10% loss. This is 30 watts out of the original 300. The formula for resistive loss is $I^2R = \text{watts}$ when $I = \text{Intensity (current in amps)}$ and $R = \text{Resistance (in ohms)}$.

$$\begin{aligned}(10 \text{ amps}) \times (10 \text{ amps}) \times R \text{ (ohms)} &= 30 \text{ watts} \\ 100 \text{ amps} \times R \text{ (ohms)} &= 30 \text{ watts} \\ R &= 30 \text{ watts}/100 \text{ amps} \\ R &= 0.3 \text{ ohms}\end{aligned}$$

This is the wire resistance that will produce a 10% loss. The wire loss chart shows loss per 1000', so:

$$1000'/200' \times 0.3 \text{ ohms} = 1.5 \text{ ohms per } 1000'.$$

The chart shows 12 ga. Wire has a resistance of 1.62 ohms per 1000', so:

$$\begin{aligned}200'/1000' \times 1.62 \text{ ohms} &= 0.32 \text{ ohms. This is close to the desired level.} \\ 10 \text{ amps} \times 10 \text{ amps} \times 0.32 \text{ ohms} &= 32 \text{ watts of loss.}\end{aligned}$$

Increasing the wire size further would reduce the losses. Voltage drop in the wire is equal to:

$$IR = 10 \text{ amps} \times 0.32 \text{ ohms} = 1.6 \text{ volts}$$

So if the battery voltage is 26.8 the generator will be operating at 30.0 volts. Keep in mind that it is always the batteries that determine the system voltage. That is, all voltages in the system rise and fall according to the battery's state of charge.

At the site, we would be generating 10 amps continuously. If we use lead acid batteries and wish to have two days of storage capacity, then:

$$10 \text{ amps} \times 24 \text{ hrs} \times 2 \text{ days} = 48 \text{ amp. Hrs. Capacity}$$

We would probably use an inverter and load controller with the system. The diagram for such a system would look like this:

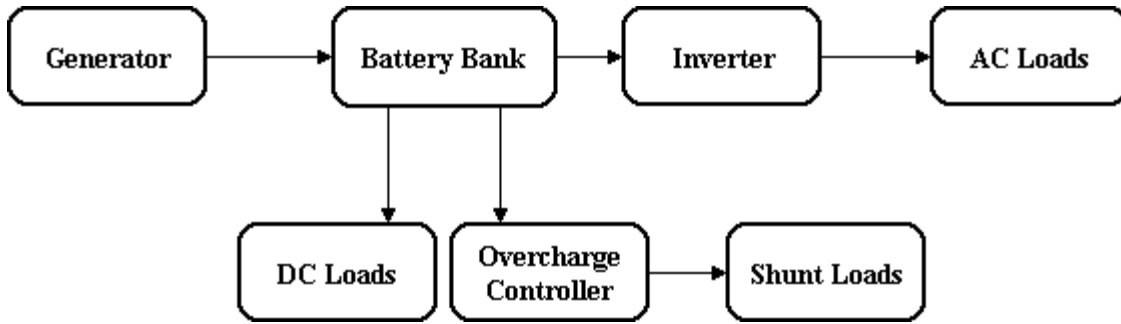

Diagram of a typical battery-based system:

OUTPUT ADJUSTMENT

For the machine to produce the highest output, the rotor height should be adjusted. This involves raising and lowering the rotor to increase the magnetic flux level. This is necessary to match the output of the turbine with that of the generator.

After the machine is installed, perform an initial run to establish a power output level. This can be determined using an ammeter to measure current or a digital meter to measure voltage. A good idea is to keep a logbook to note any output changes in relation to settings. After everything is hooked up, start the machine by opening the stop valve. Run it long enough for the output level to stabilize and note the current (or voltage). Then shut the stop valve.

The machine comes with the rotor set very close to the stator (the stationary part of the machine). To increase this distance and reduce the magnetic flux level, you must turn the larger bolt with the 19mm (3/4") head on the top of the rotor clockwise, while holding the rotor stationary. This is done by inserting the 1/4" pin supplied in one of the holes in the edge of the rotor. Then the smaller 11mm (7/16") head bolt is loosened. Now you can turn the larger bolt, which will force the rotor up. Each full turn of the bolt will move the rotor vertically 1.25 mm (0.050"). If raising the rotor causes the current (or the voltage) to increase, then continue to do so until there is no longer an increase. If a point is reached where a decrease occurs, then the rotor should be lowered. This is done by loosening the larger bolt and then tightening the smaller one. Turning the smaller bolt causes the rotor to move vertically the same distance per turn as the larger bolt does. When you have found the best position (no increase in current or voltage), make sure the larger bolt is turned until it is tight. Now the smaller bolt should be tightened securely to lock everything in place. No further adjustments should be required unless nozzle sizes are changed.

When adjusting the rotor downward, it may reach the point where it will contact the stator. If this occurs, always adjust it upwards by at least a 1/4 turn of the larger bolt. Operating the machine with the rotor closer than this may damage the machine.

**** Always turn the rotor by hand before starting the machine to check for rubbing**.**

Remove the pin in the rotor edge before starting the machine.

High Voltage models Only

When operating a Stream Engine using transformers, it will require a different technique in order to optimize the output. This can be done at the turbine by adjusting for maximum voltage rather than maximum current. AC voltage can be measured across any two of the output terminals. These terminals are the same on the terminal board as for low-voltage DC systems. Make rotor air gap adjustments according to the instructions earlier in this manual. An on/off switch is supplied in the transformer panel for the incoming AC power. In normal use the switch is left on.

DETERMINING NOZZLE SIZE

Optimal nozzle size can be determined from the design example using the Nozzle Flow Chart.

Two types of turbine runners are offered for the Stream Engine. A standard turgo runner and a high head low flow runner.

The standard turgo runner can use nozzles of up to one inch in diameter. This is used for higher flow sites which are associated with lower heads. The universal type of nozzle is supplied with the conventional runner. With the universal nozzle, it is possible to create any size nozzle jet that might be required by simply cutting the nozzle to the appropriate length. Cutting can be done with a hacksaw, or any other fine toothed saw. The end of the nozzle should then be finished with a piece of sandpaper. This is best done by placing the sandpaper on a flat surface and moving the nozzle against it. Markings are on the nozzle to assist in cutting to the correct size. The numbers are in millimeters and correspond to inches as follows:

| | | | | | | | | | | |
|--------|-----|------|-----|------|-----|-----|-----|-----|-----|----|
| mm | 3 | 4.5 | 6 | 8 | 10 | 13 | 16 | 19 | 22 | 25 |
| inches | 1/8 | 3/16 | 1/4 | 5/16 | 3/8 | 1/2 | 5/8 | 3/4 | 7/8 | 1 |

The low flow runner comes with brass nozzle inserts that are supplied in sizes of 1/8" to 1/2" in increments of 1/16" which are screwed into a plastic flange.

Both the standard Stream Engine and the low flow version are supplied with nozzle flanges that have a 1 1/2" pipe thread that is connected to the incoming plumbing.

NOZZLE FLOW CHART FLOW RATE IN U.S. GALLONS PER MINUTE

| Head Feet | Pressure PSI | Nozzle Diameter, inches | | | | | | | | | | Turbine RPM | |
|------------|--------------|-------------------------|------|------|------|------|------|------|------|------|------|-------------|-------------|
| | | 1/8 | 3/16 | 1/4 | 5/16 | 3/8 | 7/16 | 1/2 | 5/8 | 3/4 | 7/8 | | 1.0 |
| 5 | 2.2 | | | | | 6.18 | 8.40 | 11.0 | 17.1 | 24.7 | 33.6 | 43.9 | 460 |
| 10 | 4.3 | | | 3.88 | 6.05 | 8.75 | 11.6 | 15.6 | 24.2 | 35.0 | 47.6 | 62.1 | 650 |
| 15 | 6.5 | | 2.68 | 4.76 | 7.40 | 10.7 | 14.6 | 19.0 | 29.7 | 42.8 | 58.2 | 76.0 | 800 |
| 20 | 8.7 | 1.37 | 3.09 | 5.49 | 8.56 | 12.4 | 16.8 | 22.0 | 34.3 | 49.4 | 67.3 | 87.8 | 925 |
| 30 | 13.0 | 1.68 | 3.78 | 6.72 | 10.5 | 15.1 | 20.6 | 26.9 | 42.0 | 60.5 | 82.4 | 107 | 1140 |
| 40 | 17.3 | 1.94 | 4.37 | 7.76 | 12.1 | 17.5 | 23.8 | 31.1 | 48.5 | 69.9 | 95.1 | 124 | 1310 |
| 50 | 21.7 | 2.17 | 4.88 | 8.68 | 13.6 | 19.5 | 26.6 | 34.7 | 54.3 | 78.1 | 106 | 139 | 1470 |
| 60 | 26.0 | 2.38 | 5.35 | 9.51 | 14.8 | 21.4 | 29.1 | 38.0 | 59.4 | 85.6 | 117 | 152 | 1600 |
| 80 | 34.6 | 2.75 | 6.18 | 11.0 | 17.1 | 24.7 | 33.6 | 43.9 | 68.6 | 98.8 | 135 | 176 | 1850 |
| 100 | 43.3 | 3.07 | 6.91 | 12.3 | 19.2 | 27.6 | 37.6 | 49.1 | 76.7 | 111 | 150 | 196 | 2070 |
| 120 | 52.0 | 3.36 | 7.56 | 13.4 | 21.0 | 30.3 | 41.2 | 53.8 | 84.1 | 121 | 165 | 215 | 2270 |
| 150 | 65.0 | 3.76 | 8.95 | 15.0 | 23.5 | 33.8 | 46.0 | 60.1 | 93.9 | 135 | 184 | 241 | 2540 |
| 200 | 86.6 | 4.34 | 9.77 | 17.4 | 27.1 | 39.1 | 53.2 | 69.4 | 109 | 156 | 213 | 278 | 2930 |
| 250 | 108 | 4.86 | 10.9 | 19.9 | 30.3 | 43.6 | 59.4 | 77.6 | 121 | 175 | 238 | 311 | 3270 |
| 300 | 130 | 5.32 | 12.0 | 21.3 | 33.2 | 47.8 | 65.1 | 85.1 | 133 | 191 | 261 | 340 | 3591 |
| 400 | 173 | 6.14 | 13.8 | 24.5 | 38.3 | 55.2 | 75.2 | 98.2 | 154 | 221 | 301 | 393 | 4140 |

BEARINGS, SERVICE & ASSEMBLY

In order to remove the generator you must first remove the turbine wheel. The machine's wheel is unscrewed from the shaft by holding the rotor using the 1/4" diameter rod inserted into one of the holes in the edge of the rotor. The turbine wheel is assembled with a washer and then a spacer on top. The shaft is made with standard right hand threads for the turbine wheel so it will unscrew in a counter-clockwise direction when looking at the shaft (with the machine upside down). Then you can remove the four bolts that hold the base of the generator with a 4mm (5/32") hex drive.

IMPORTANT Bearing maintenance is important. You should replace bearings **ONCE PER YEAR** or as soon as you notice any looseness from wear. If they are too loose, severe damage to both the rotor and the stator can result. Check the clearance often making sure you can insert something the thickness of a business card between the rotor magnets and the stator. Even if the bearings are not worn, changing them once per year will help keep the area free of corrosion and make future bearing changes easier. This machine uses three 6203 ball bearings with contact seals. Presently the bearings in the machine are a slip fit in the housing bore and can be replaced by hand IF there is not too much corrosion. The use of a press may be required if the bearings are stuck in the housing.

To replace bearings:

1. Using the rotor pin to hold the shaft, unthread the runner from the generator shaft.
2. Remove rotor. To remove rotor and shaft raise the rotor as described in *output adjustment* until the magnetic attraction is low enough to separate the rotor/shaft assembly from the housing and stator.
3. Unscrew two bolts and washers that retain the bearings.
4. With the Stream Engine sitting inverted, using your thumbs, push out the bearings from the housing or tap the bearings out. This may require a press in some situations.
5. Clean bearing sleeve and insert new 6203 bearings.
6. Reassemble.

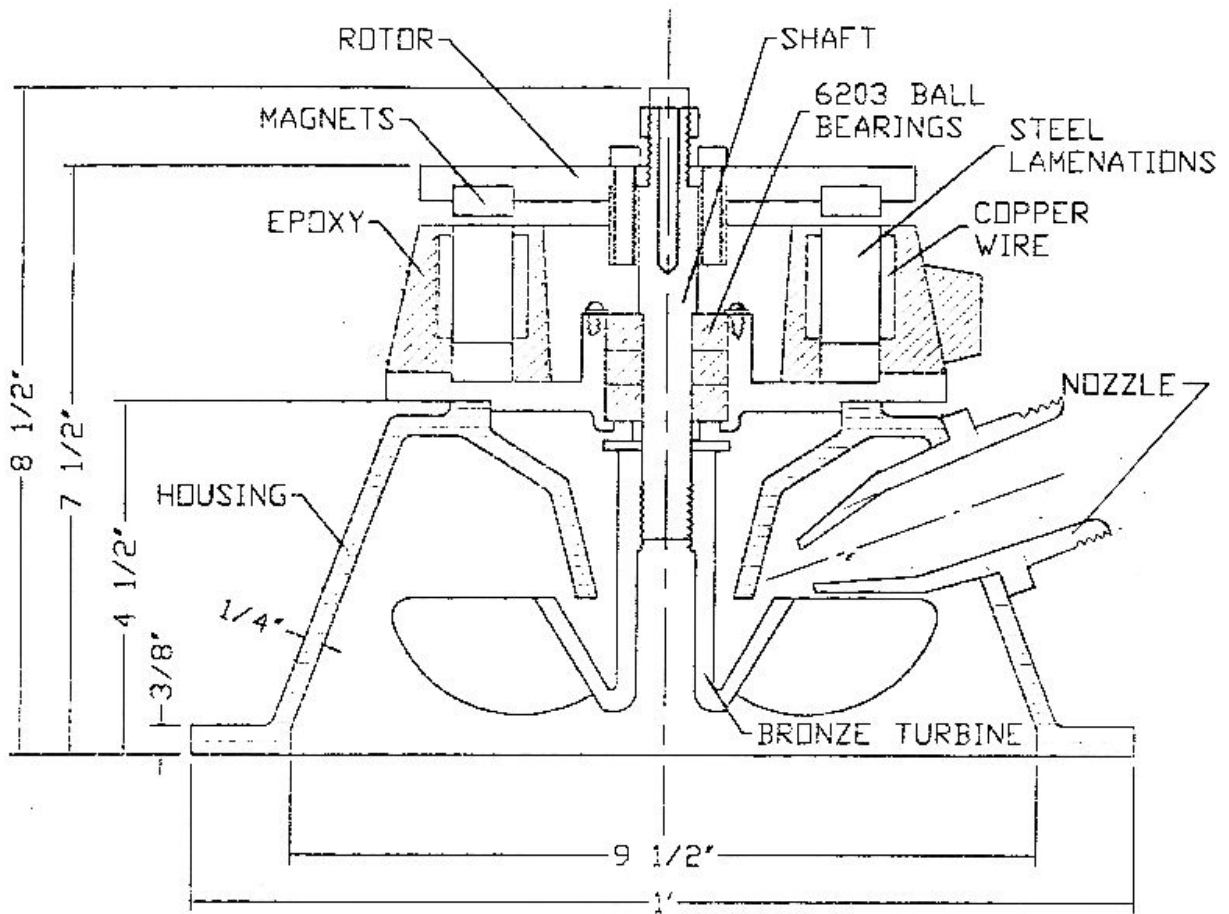

Copper Wire Resistance Chart

| Wire Gauge | Diameter Inches | Ohms per 1000' | Ohms per Mile |
|------------|-----------------|----------------|---------------|
| 0000 | 0.460 | 0.05 | 0.26 |
| 000 | 0.410 | 0.06 | 0.33 |
| 00 | 0.364 | 0.08 | 0.42 |
| 0 | 0.324 | 0.10 | 0.52 |
| 2 | 0.258 | 0.16 | 0.84 |
| 4 | 0.204 | 0.25 | 1.34 |
| 6 | 0.162 | 0.40 | 2.13 |
| 8 | 0.128 | 0.64 | 3.38 |
| 10 | 0.102 | 1.02 | 5.38 |
| 12 | 0.081 | 1.62 | 8.56 |
| 14 | 0.064 | 2.58 | 13.6 |
| 16 | 0.051 | 4.10 | 21.6 |
| 18 | 0.040 | 6.52 | 34.4 |

PIPE FRICTION LOSS - PVC Class 160 PSI Plastic Pipe

Pressure Loss from Friction in Feet of Head per 100 Feet of Pipe

| Flow US GPM | <i>Pipe Diameter, Inches</i> | | | | | | | | | | |
|-------------|------------------------------|------|------|------|------|------|------|------|------|------|------|
| | 1 | 1.25 | 1.5 | 2 | 2.5 | 3 | 4 | 5 | 6 | 8 | 10 |
| 1 | 0.05 | 0.02 | | | | | | | | | |
| 2 | 0.14 | 0.05 | 0.02 | | | | | | | | |
| 3 | 0.32 | 0.09 | 0.04 | | | | | | | | |
| 4 | 0.53 | 0.16 | 0.09 | 0.02 | | | | | | | |
| 5 | 0.80 | 0.25 | 0.12 | 0.04 | | | | | | | |
| 6 | 1.13 | 0.35 | 0.18 | 0.07 | 0.02 | | | | | | |
| 7 | 1.52 | 0.46 | 0.23 | 0.08 | 0.02 | | | | | | |
| 8 | 1.93 | 0.58 | 0.30 | 0.10 | 0.04 | | | | | | |
| 9 | 2.42 | 0.71 | 0.37 | 0.12 | 0.05 | | | | | | |
| 10 | 2.92 | 0.87 | 0.46 | 0.16 | 0.07 | 0.02 | | | | | |
| 11 | 3.50 | 1.04 | 0.53 | 0.18 | 0.07 | 0.02 | | | | | |
| 12 | 4.09 | 1.22 | 0.64 | 0.20 | 0.09 | 0.02 | | | | | |
| 14 | 5.45 | 1.63 | 0.85 | 0.28 | 0.12 | 0.04 | | | | | |
| 16 | 7.00 | 2.09 | 1.08 | 0.37 | 0.14 | 0.04 | | | | | |
| 18 | 8.69 | 2.60 | 1.33 | 0.46 | 0.18 | 0.07 | | | | | |
| 20 | 10.6 | 3.15 | 1.63 | 0.55 | 0.21 | 0.09 | 0.02 | | | | |
| 22 | 12.6 | 3.77 | 1.96 | 0.67 | 0.25 | 0.10 | 0.02 | | | | |
| 24 | 14.8 | 4.42 | 2.32 | 0.78 | 0.30 | 0.12 | 0.04 | | | | |
| 26 | 17.2 | 5.13 | 2.65 | 0.90 | 0.35 | 0.14 | 0.05 | | | | |
| 28 | 19.7 | 5.89 | 3.04 | 1.04 | 0.41 | 0.16 | 0.05 | | | | |
| 30 | 22.4 | 6.70 | 3.45 | 1.17 | 0.43 | 0.18 | 0.05 | | | | |
| 35 | | 8.90 | 4.64 | 1.56 | 0.62 | 0.23 | 0.07 | | | | |
| 40 | | 11.4 | 5.89 | 1.98 | 0.78 | 0.30 | 0.09 | 0.02 | | | |
| 45 | | 14.2 | 7.34 | 2.48 | 0.97 | 0.37 | 0.12 | 0.04 | | | |
| 50 | | 17.2 | 8.92 | 3.01 | 1.20 | 0.46 | 0.14 | 0.04 | | | |
| 55 | | 20.5 | 10.6 | 3.59 | 1.43 | 0.55 | 0.16 | 0.05 | | | |
| 60 | | 24.1 | 12.5 | 4.21 | 1.66 | 0.64 | 0.18 | 0.07 | 0.02 | | |
| 70 | | | 16.6 | 5.61 | 2.21 | 0.85 | 0.25 | 0.09 | 0.03 | | |
| 80 | | | 21.3 | 7.18 | 2.83 | 1.08 | 0.32 | 0.12 | 0.04 | | |
| 90 | | | | 8.92 | 3.52 | 1.36 | 0.39 | 0.14 | 0.07 | | |
| 100 | | | | 10.9 | 4.28 | 1.66 | 0.48 | 0.18 | 0.07 | 0.02 | |
| 150 | | | | 23.2 | 9.06 | 3.50 | 1.04 | 0.37 | 0.16 | 0.05 | |
| 200 | | | | | 15.5 | 5.96 | 1.75 | 0.62 | 0.28 | 0.07 | 0.02 |
| 250 | | | | | 23.4 | 9.05 | 2.65 | 0.94 | 0.42 | 0.12 | 0.05 |
| 300 | | | | | | 12.6 | 3.73 | 1.34 | 0.58 | 0.16 | 0.05 |
| 350 | | | | | | 16.8 | 4.95 | 1.78 | 0.76 | 0.21 | 0.07 |
| 400 | | | | | | 21.5 | 6.33 | 2.25 | 0.97 | 0.28 | 0.10 |
| 450 | | | | | | | 7.87 | 2.81 | 1.20 | 0.32 | 0.12 |
| 500 | | | | | | | 9.55 | 3.41 | 1.45 | 0.42 | 0.14 |
| 550 | | | | | | | 11.4 | 4.07 | 1.75 | 0.48 | 0.16 |
| 600 | | | | | | | 13.4 | 4.78 | 2.05 | 0.58 | 0.18 |
| 650 | | | | | | | 15.5 | 5.54 | 2.37 | 0.67 | 0.23 |
| 700 | | | | | | | 17.8 | 6.37 | 2.71 | 0.76 | 0.25 |
| 750 | | | | | | | 20.3 | 7.22 | 3.10 | 0.86 | 0.30 |
| 800 | | | | | | | | 8.14 | 3.50 | 0.97 | 0.32 |
| 850 | | | | | | | | 9.11 | 3.89 | 1.08 | 0.37 |
| 900 | | | | | | | | 10.1 | 4.32 | 1.20 | 0.42 |
| 950 | | | | | | | | 10.8 | 4.79 | 1.34 | 0.46 |
| 1000 | | | | | | | | 12.3 | 5.27 | 1.45 | 0.51 |

PIPE FRICTION LOSS Polyethylene SDR - Pressure Rated Pipe
 Pressure Loss from Friction in Feet of Head per 100 Feet of Pipe

| Flow US GPM | Pipe Diameter, Inches | | | | | | | |
|-------------|-----------------------|------|------|------|------|------|------|------|
| | 0.5 | 0.75 | 1 | 1.25 | 1.5 | 2 | 2.5 | 3 |
| 1 | 1.13 | 0.28 | 0.09 | 0.02 | | | | |
| 2 | 4.05 | 1.04 | 0.32 | 0.09 | 0.04 | | | |
| 3 | 8.60 | 2.19 | 0.67 | 0.19 | 0.09 | 0.02 | | |
| 4 | 14.6 | 3.73 | 1.15 | 0.30 | 0.14 | 0.05 | | |
| 5 | 22.1 | 5.61 | 1.75 | 0.46 | 0.21 | 0.07 | | |
| 6 | 31.0 | 7.89 | 2.44 | 0.65 | 0.30 | 0.09 | 0.05 | |
| 7 | 41.2 | 10.5 | 3.24 | 0.85 | 0.42 | 0.12 | 0.06 | |
| 8 | 53.1 | 13.4 | 4.14 | 1.08 | 0.51 | 0.16 | 0.07 | |
| 9 | | 16.7 | 5.15 | 1.36 | 0.65 | 0.18 | 0.08 | |
| 10 | | 20.3 | 6.28 | 1.66 | 0.78 | 0.23 | 0.09 | 0.02 |
| 12 | | 28.5 | 8.79 | 2.32 | 1.11 | 0.32 | 0.14 | 0.05 |
| 14 | | 37.9 | 11.7 | 3.10 | 1.45 | 0.44 | 0.18 | 0.07 |
| 16 | | | 15.0 | 3.93 | 1.87 | 0.55 | 0.23 | 0.08 |
| 18 | | | 18.6 | 4.90 | 2.32 | 0.69 | 0.30 | 0.09 |
| 20 | | | 22.6 | 5.96 | 2.81 | 0.83 | 0.35 | 0.12 |
| 22 | | | 27.0 | 7.11 | 3.36 | 1.00 | 0.42 | 0.14 |
| 24 | | | 31.7 | 8.35 | 3.96 | 1.17 | 0.49 | 0.16 |
| 26 | | | 36.8 | 9.68 | 4.58 | 1.36 | 0.58 | 0.21 |
| 28 | | | | 11.1 | 5.25 | 1.56 | 0.67 | 0.23 |
| 30 | | | | 12.6 | 5.96 | 1.77 | 0.74 | 0.25 |
| 35 | | | | 16.8 | 7.94 | 2.35 | 1.00 | 0.35 |
| 40 | | | | 21.5 | 10.2 | 3.02 | 1.27 | 0.44 |
| 45 | | | | 26.8 | 12.7 | 3.75 | 1.59 | 0.55 |
| 50 | | | | 32.5 | 15.4 | 4.55 | 1.91 | 0.67 |
| 55 | | | | | 18.3 | 5.43 | 1.96 | 0.81 |
| 60 | | | | | 21.5 | 6.40 | 2.70 | 0.94 |
| 65 | | | | | 23.8 | 7.41 | 3.13 | 1.08 |
| 70 | | | | | 28.7 | 8.49 | 3.59 | 1.24 |
| 75 | | | | | 32.6 | 9.67 | 4.07 | 1.40 |
| 80 | | | | | | 10.9 | 4.58 | 1.59 |
| 85 | | | | | | 12.2 | 5.13 | 1.77 |
| 90 | | | | | | 13.5 | 5.71 | 1.98 |
| 95 | | | | | | 15.0 | 6.31 | 2.19 |
| 100 | | | | | | 16.5 | 6.92 | 2.42 |
| 150 | | | | | | 34.5 | 14.7 | 5.11 |
| 200 | | | | | | | 25.0 | 8.70 |

WIRING DIAGRAMS

These diagrams represent the four possible combinations of output wiring. They are in order of potential. If you find your air gap adjustment to be at a minimum and wish to try for more power, then try using the next higher combination. If you find the air gap is very large, try the next lower one. Note that there is only a small change in potential between #2 to #3.

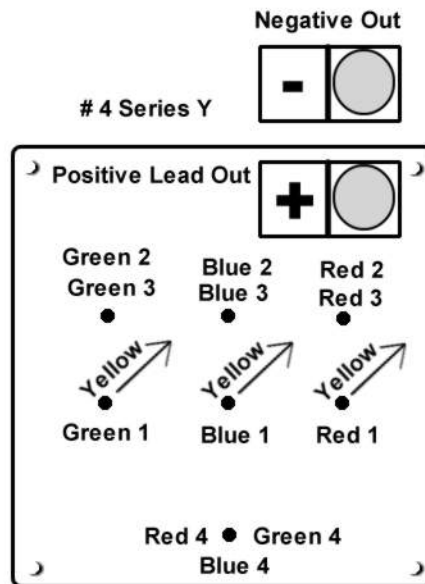
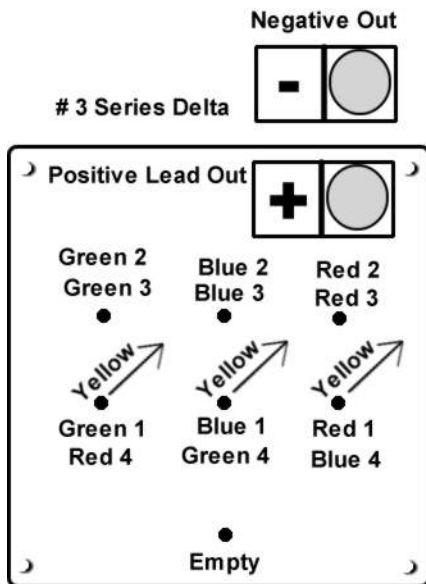
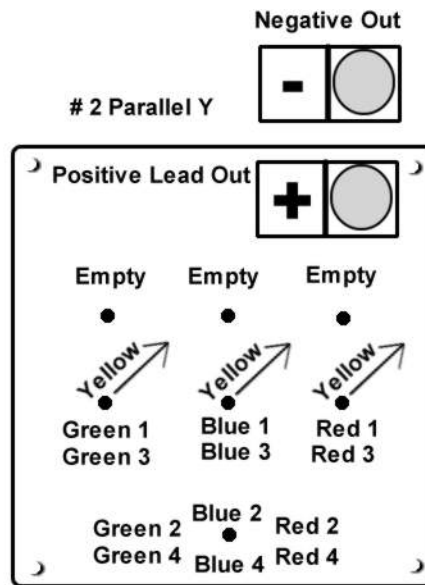
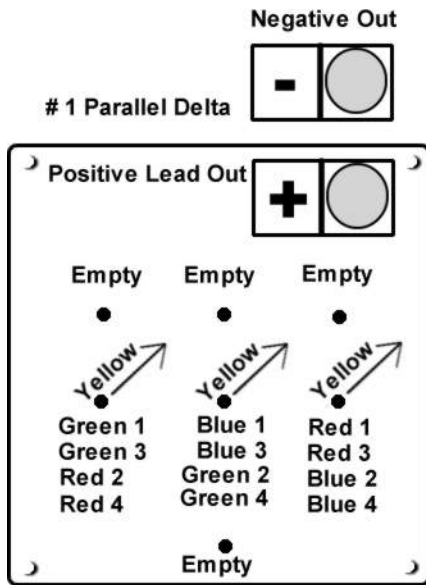

WIRING SCHEMES

| <i>12 VOLTS</i> | <i>24 VOLTS</i> | <i>48 VOLTS</i> |
|------------------------------------|--|--|
| Parallel Delta All Heads | Series Delta <i>up to 60'/18 m</i> | Series Y <i>up to 60'/ 18m</i> |
| | Parallel Delta <i>30'/ 9m and up</i> | Series Delta <i>30'/9m to 250'/75m</i> |
| | | Parallel Delta <i>140'/43m and up</i> |

Note: At a given site, more than one scheme may work. But one will work best.

Parallel wye configuration is not mentioned because it is very similar to series delta. It differs by about 15%. If you have a site where series delta is used and you think the output could be greater, try it. Remember to adjust the rotor for highest output when changing the wiring.

CURRENT MEASUREMENT TECHNIQUE

A built-in shunt (precision resistance) is installed in the junction box which allows the current to be measured digitally. This is done with the supplied DMM (digital multi meter). To measure the current produced by the generator, set the DMM scale to "DC milli-volts" or "200 m". **Do not use the amps scale.** Plug the leads into their corresponding color-coded jacks on the shunt in the junction box. This will give current readings from 0.1 amps to 99.9 amps. Of course, the DMM can be used for other tasks with your renewable energy system.

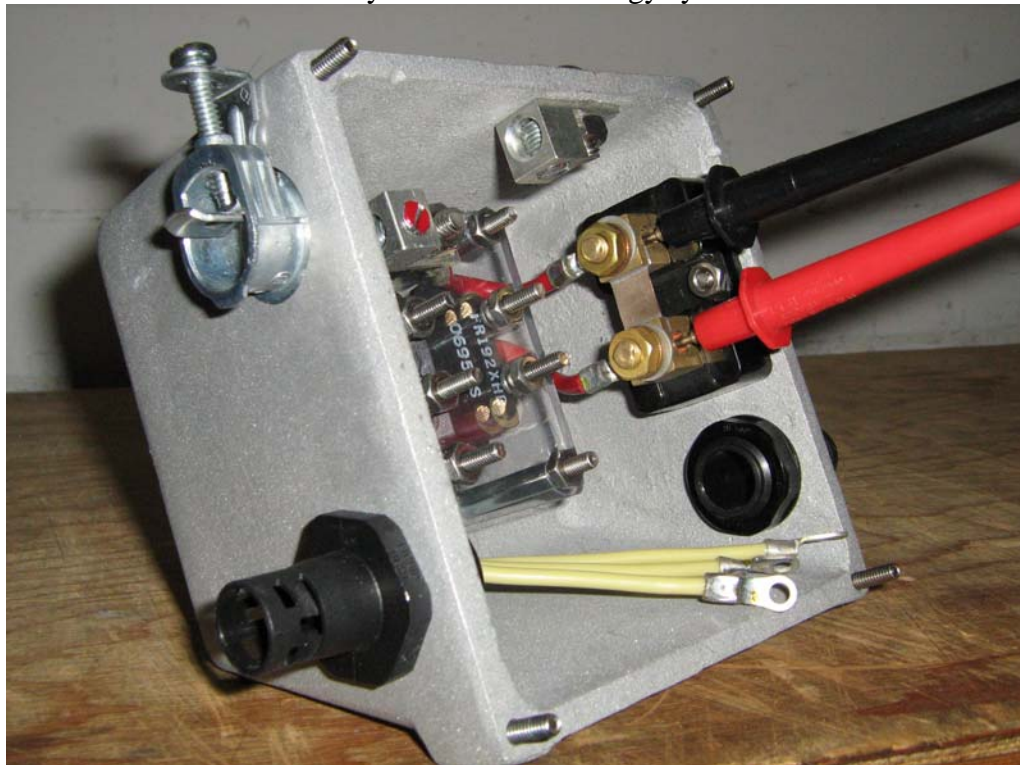

INSTALLATION EXAMPLES

A Stream Engine installed using PVC pipe and union valves.



Under construction; a 30' head site shown before gravel base was added. Installation with flexible pipe. Note the pipe is attached to the nozzles using hose clamps.



Note pressure gauge installed by drilling and tapping the T fitting and using a small valve. This allows removal of the gauge to prevent freezing damage to the gauge.



Following is an example of what **NOT** to do for a Stream Engine installation. An installation of this sort will result in a huge loss of power. To optimize the output of the generator all aspects of installation should be well done. It is important to pay attention to plumbing, nozzle size, intake conditions, siting, electrical components, as well as regular maintenance.

